

D12180

DATA SHEET



Float AGM Battery Block

Discover® AGM Series VRLA Industrial Batteries provide superior high integrity and reliability for commercial, industrial, and private applications. The maintenance-free Valve Regulated Lead Acid (VRLA) construction make Discover® Standard AGM Series Batteries the definitive choice for broadband and CableTV (CATV), Uninterruptible Power Supplies (UPS), telecommunications, and electronics and security applications.

Mechanical Drawings

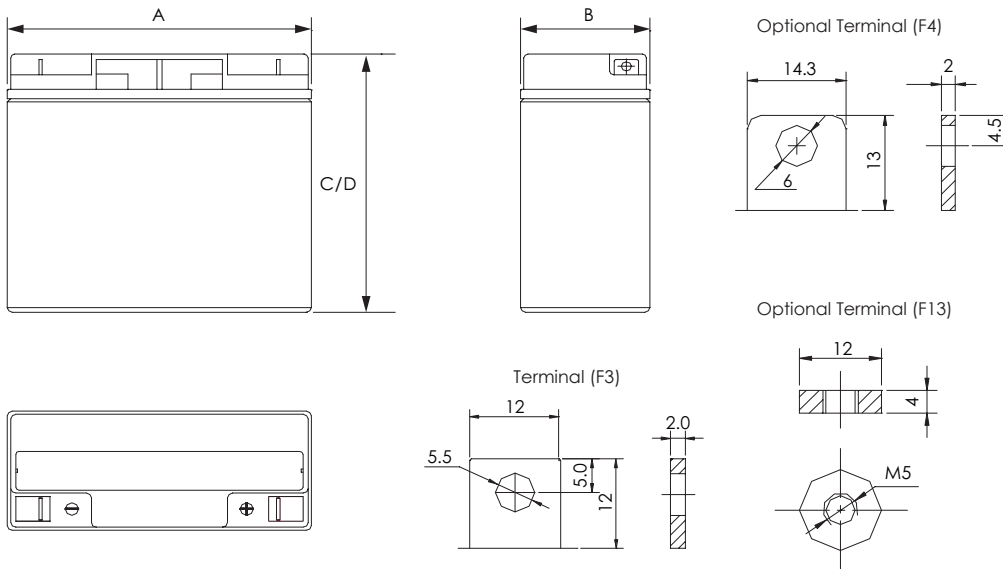

Benefits and Features

- Tank formed lead-tin-calcium plates deliver consistent dependable performance and promote long life
- Maintenance-free technology
- 99% gas recombination for extended life in float applications
- Multiple terminal, configuration options and carrying handles available with most models
- Classified as a non-spillable battery and is not restricted for transportation by:
 - Air (IATA/ICAO provision 67)
 - Surface (DOT-CFR-HMR49)
 - Water (per IMDG amendment 27)
- Flame retardant ABS case and cover with UL94 V0 rating available
- UL924 recognized flame arresting low pressure safety vents
- 98% recyclable
- Up to 12 year design life in float service

Mechanical Specifications

Length (A)	7.1 in	181 mm
Width (B)	3 in	77 mm
Height (C)	6.6 in	167 mm
Total Height (D)	6.6 in	167 mm
Weight	11.35 lbs	5.16 kgs
Terminal (Opt'l)	F3 (F4) (F13)	
Cells	6	
Electrolyte	AGM	

TERMINAL TORQUE: Please refer to our document, located in the Resources webpage (www.discover-energy.com/resources/).

CAUTION: Extra considerations must be given to depths of discharge, operating voltages and currents when designing systems for use at maximum temperatures.

Electrical Specifications

Voltage	12 V
Internal Resistance	16 mΩ
Short Circuit 20°C (68°F)	-
20 HR	17.0 Ah
10 HR	16.2 Ah
5 HR	14.5 Ah
1 HR	11.0 Ah
15 MIN	-
Charge Temperatures	-10°C (14°F) to 50°C (122°F)
Discharge Temperatures	-20°C (-4°F) to 50°C (122°F)
Maximum Discharge*	-40°C (-40°F) to 60°C (140°F)

Certifications and Standards

Designed in accordance with and published in compliance with applicable BCI, IEC and BS EN standards, including:

- IEC60896-21/22
- BS EN 60254-1:2005
- AS/NZS 4029.2:2000 BS EN 60254-1:2005 (MOD)

Discover® and its facilities and products are certified to multiple standards:

- ISO, UL, QS, and TUV standards
- EITS Germany
- Euro Bat classification for Environmental Stewardship Standards



Contact Us



#4 -13511 Crestwood Place,
Richmond, BC, V6V 2E9, Canada
Email: info@discover-energy.com
www.discover-energy.com

Discharge Constant Current (Amperes at 25°C/77°F)

End Point V/C	5 MIN	10 MIN	15 MIN	30 MIN	1 HR	3 HR	5 HR	10 HR	20 HR
1.60V	63.7	42.8	32.6	19.2	11.0	4.49	3.05	1.70	0.90
1.65V	61.4	41.8	31.8	18.8	10.7	4.40	3.00	1.68	0.89
1.70V	59.1	40.8	31.0	18.4	10.4	4.30	2.95	1.66	0.88
1.75V	56.8	39.6	30.2	18.0	10.0	4.21	2.90	1.64	0.86
1.80V	54.5	38.6	29.4	17.5	9.7	4.12	2.85	1.62	0.85

Discharge Constant Power (Watts at 25°C/ 77°F)

End Point V/C	5 MIN	10 MIN	15 MIN	30 MIN	45 MIN	1 HR	2 HR	3 HR	5 HR
1.60V	129	81.7	64.9	38.0	27.8	22.4	14.5	10.5	6.57
1.65V	125	79.2	63.4	36.8	26.8	21.5	13.6	9.84	6.57
1.70V	120	76.0	60.8	35.6	25.6	20.4	12.8	9.09	6.24
1.75V	113	72.7	58.3	34.3	24.5	19.3	12.0	8.29	5.89
1.80V	107	69.3	56.0	32.9	23.1	18.0	10.9	7.38	5.46

Charge and Discharge

Max Charge / Discharge Currents	Peak (5 seconds)	Peak (10 seconds)	Max Continuous
Charge	1c20	0.75c20	0.25c20
Discharge	15c20	10c20	0.5c20

Float (Stand-By) Use: Hold a constant voltage of 2.25vpc to 2.30vpc continuously. When held at this voltage, the battery will seek its own current level and maintain itself in a fully charged condition.

Cyclic Use: Limit initial currents to 0.25C20 amps. Charge until battery voltage reaches 2.40 to 2.45vpc. Hold at 2.40 to 2.45vpc until current drops to under 0.01C20 amps. Battery is fully charged under these conditions, and charger should be disconnected or switched to "float" voltage.

Temperature Coefficient: Adjust charging voltage to +/- 0.005vpc (C, 0.003vpc/F) from 25°C (77°F).

Discharge Characteristics (20°C/68°F)

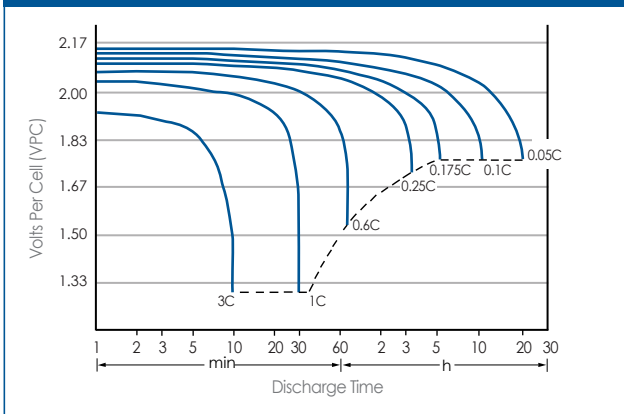

Self-Discharge Characteristics

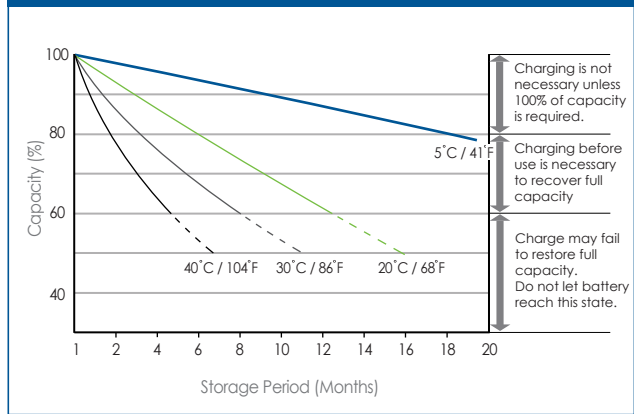

Life Characteristics in Stand-By Use

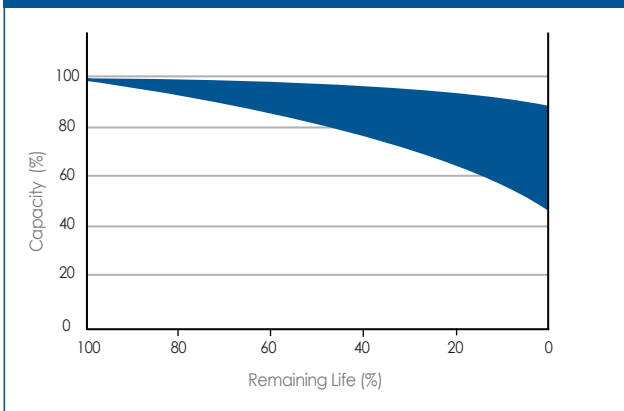

Life Characteristics in Cyclic Use (Cyclic Models Only)

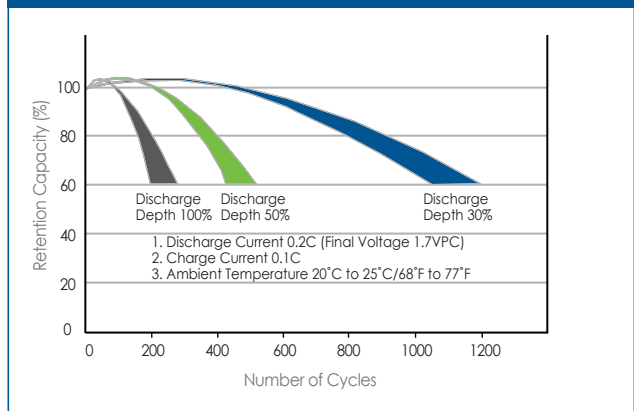

Temperature Effects on Capacity

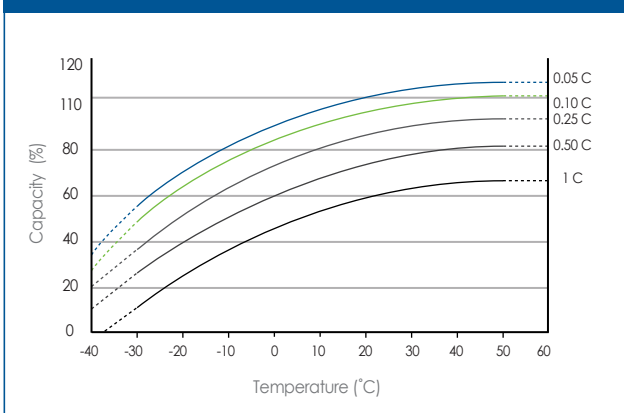

Temperature Effects on Float Life

